

- o TRUE ZERO SPEED
- o ALL STEEL GEARS 4-24 PITCH
- o TEMPERATURE STABLE

ENVIRONMENTAL SPECIFICATIONS - S63B	
Corrosion Resistance	500 hours salt spray ASTM B-117
Installation Torque	80 Foot-Pounds Maximum
Enclosure	Nema 1,3,4,6,13 & IEC IP67
Vibration	10 G's 2 to 2000 Hz Sinusoidal
Mechanical Shock	100 G's, 11 ms Half-Sine

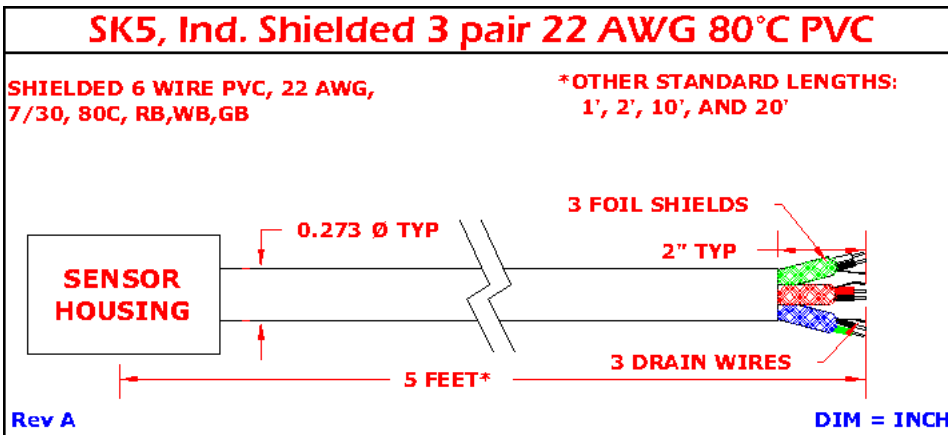
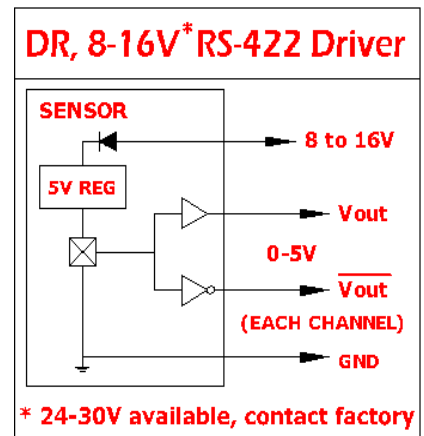
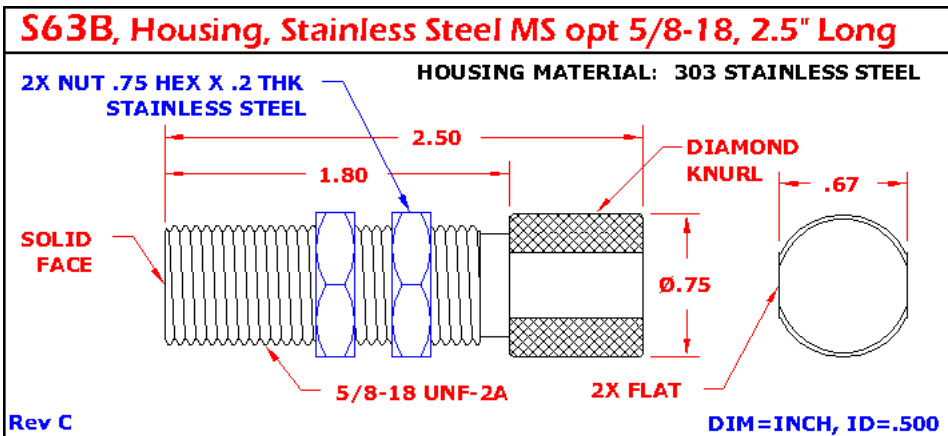

Connections Chart	
Red/Black	Vcc / Gnd
White/Black	CH A / CH A
Green/Black	CH B / CH B
Drain	Shield Only
SK5-37ADQ	

Date Code 'YYM'			
YY = YEAR, M = MONTH			
A JAN	D APR	H JUL	L OCT
B FEB	E MAY	J AUG	M NOV
C MAR	G JUN	K SEP	N DEC

The 37ADQ Quadrature Speed Sensor provides 2 digital outputs as gear teeth rotate by the sensor's face. These sensors have 2 internal sensing elements that are physically placed 1/4, 3/4 or 1 1/4 tooth apart. The quadrature phase angle (phase shift from channel A to channel B) ideally should be 90 degrees. This will only happen if the correct gear pitch is used, and the sensor is aligned correctly with the target's rotation direction. Therefore, when ordering this sensor, it cannot be built until the factory receives the gear pitch for the intended target.

Gear pitch = (the # of teeth on the gear) / (the gear's contact diameter in inches)

Specifications may not be valid when the application is not detecting an end-sensed, 14.5 pressure angle, steel spur gear. The presence of ferrous metals or strong magnetic fields in close proximity to the sensor's internal magnet may also invalidate the specifications. Engineers are available to assist in target design and applications with non-standard targets. Custom target specifications can only be guaranteed when the customer supplies a target along with any additional components that may affect sensor output, and the customer has validated function in the finished application.

The 37ADQ sensor is a true zero speed Hall Effect Gear Tooth sensor which will never miss a pulse, and is the best choice for detecting 4-24 pitch gears with evenly spaced teeth. The 37ADQO sensor is another option for quadrature speed sensing. This sensor is the best choice for detecting gears with missing or unevenly spaced teeth, as well as other targets such as bolt heads or holes in a rotating disc. Check our website or call us to discuss all of our dual output gear tooth and quadrature speed sensor options.

37ADQ-DR, Electrical & Functional Specifications

ABSOLUTE MAX LIMITS	MIN	MAX	UNITS
Supply Voltage, Vcc	-30	+30	Volts DC
Voltage applied to output	0	+5.5	Volts
Current into each output	--	50	mA
Current out of each output	--	20	mA
Total output current	--	40	mA

ELECTRICAL SPECS	CONDITIONS	MIN	MAX	UNITS
Temperature Range *	See Voltage Limits	-40	+110	Deg C
Supply Voltage, Vcc *	-40 to +110° C	+8.0	+16	Volts DC
Supply Voltage, Vcc *	-40 to +50° C	+8.0	+25	Volts DC
Supply Current *	Into Vcc	+20	+65	mA
Frequency Range	True zero speed	0	10	kHz
Vol, Low Level Vout	See asterisk *	0	0.5	Volts
Voh, High Level Vout	See asterisk *	3.4	4.2	Volts
Output Rise Time 10-90%	See asterisk *	--	500	nS
Output Fall Time 90-10%	See asterisk *	--	500	nS
ESD **	Nondestructive	--	2000	Volts
EMI **	20k to 1 G Hz	--	20	V/M

* Tested with one receiver per channel, UA9637. No termination resistor used.

** Similar Product Qualified

TARGET PERFORMANCE GEAR PITCH ~ (#Teeth/Diam. in inches)	AIR GAP RANGE***	TYPICAL MAX GAP	TYP. OUTPUT DUTY CYCLE	ALIGNMENT SKEW ANGLE
4 (.785" tooth to tooth)	.000 to .140"	.160"	40 to 60 %	±35 deg
6 (.524" tooth to tooth)	.000 to .120"	.140"	40 to 60 %	±30 deg
8 (.393" tooth to tooth)	.000 to .100"	.125"	40 to 60 %	±30 deg
12 (.262" tooth to tooth)	.000 to .075"	.100"	35 to 65 %	±25 deg
16 (.196" tooth to tooth)	.000 to .055"	.075"	35 to 65 %	±20 deg
20 (.157" tooth to tooth)	.000 to .035"	.050"	30 to 70 %	±15 deg
24 (.131" tooth to tooth)	.000 to .020"	.030"	30 to 70 %	±10 deg

Rev C

*** Non contacting

Phase Angle 5° to 175° over entire air gap range

CHARACTERISTIC-OPTION_GEAR PITCH MARKED ON THIS SURFACE, yy=OPTION, gp=GEAR PITCH (e.g. _08 = 8 PITCH GEAR)

ALIGNED AS SHOWN,
CH A LEADS CH B
FOR CW ROTATION

ORIENT FLAT
PARALLEL TO
GEAR ± SKEW ANGLE

DATE CODE,
THIS SURFACE

DO NOT CONTACT
FACE TO FACE

CONTACT WITH OTHER MAGNETS
MAY DECREASE THE SENSOR'S
MAXIMUM AIR GAP.

S63B-37ADQ