

S12-HS1-L5T21 - Hall or Magneto Resistive Switch Sensor

www.sensorso.com

Sensitive S-Pole Hall Switch, 55G, load dump & EMI protection w/ 5k pull up, Stainless 12x1mm x 35mm housing, free end Teflon 22AWG wires, 1 foot

Digital output switches on and off with a magnet.

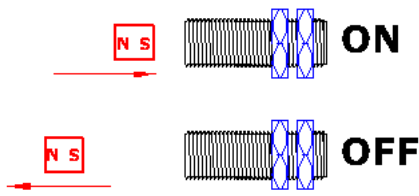

Type - HS

- o DETECT SOUTH POLE
- o OPERATES FROM 4.5 TO 24 V
- o -40 TO UP TO 150 C
- o LOWER SWITCH POINT DETECTS FARTHER THAN HS
- o CHOPPER STABILIZED HALL EFFECT

ENVIRONMENTAL SPECIFICATIONS - S12	
Corrosion Resistance	500 hours salt spray ASTM B-117
Installation Torque	23 Foot-Pounds Maximum
Enclosure	Nema 1,3,4,6,13 & IEC IP67
Vibration	10 G's 2 to 2000 Hz Sinusoidal
Mechanical Shock	100 G's, 11 ms Half-Sine

S12, Housing, Stainless Steel, M12X1, 35mm Long

HOUSING MATERIAL: 303 STAINLESS STEEL

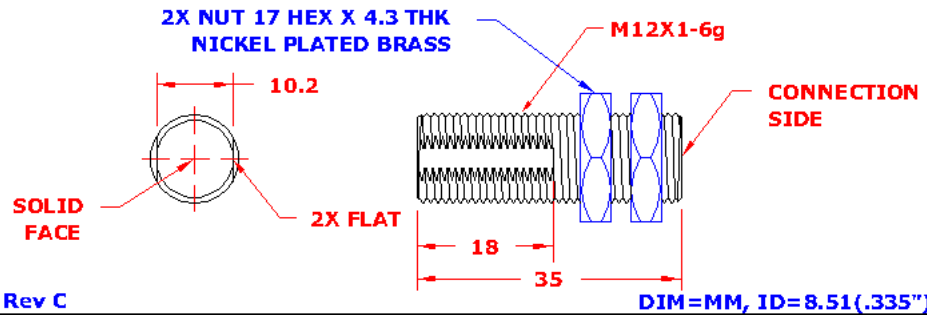

Rev C

L5, NPN with 5k Pull Up, Protection & EMI Filter

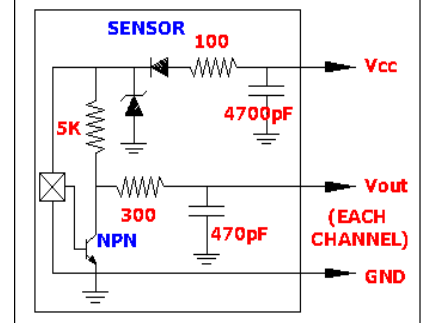

T21, Free End Teflon 22AWG Wires

FREE END WIRE LEADS

22 AWG, TEFLON 200°C, 19/34

3 WIRES SHOWN. THE NUMBER OF WIRES AND COLORS WILL VARY PER SENSOR MODEL

*OTHER STANDARD LENGTHS: 3", 6", 2', 5', 10', AND 20'

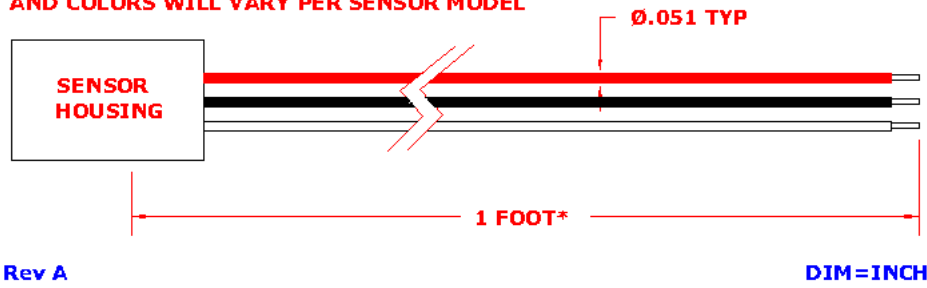

Rev A

Connections Chart

Red	Vcc
Black	Ground
White	Vout (or RELAY)
Green (if present)	RELAY COM
T21-HS1	

Date Code 'YYM'

YY = YEAR, M = MONTH

A JAN	D APR	H JUL	L OCT
B FEB	E MAY	J AUG	M NOV
C MAR	G JUN	K SEP	N DEC

The HS1 sensors provide one digital output that is normally OFF and turns ON when a magnetic field is present. The Hall Effect switch triggers from the South Pole of a magnet. Note that OUTPUT ON means LOW for NPN sensors and HIGH for PNP sensors. The HS1 is a sensitive Hall Effect switch that triggers when exposed to a field of 55 Gauss, which will allow the sensor to detect a magnet farther than HS sensors.

The distance between the sensor face and the South Pole of a magnet that operates the switch (turns the output transistor on) is referred to as the 'Operate Air Gap'. This gap is determined by looking at the magnet's flux density vs. air gap curve. The distance that produces the magnetic South Pole field equal to or less than 'Release Point' specified on this sheet is the Release air gap. The must operate air gap is the distance at which the magnet produces a South Pole field equal to the MAX operate point of the Hall switch. The must release gap is the distance the at which the magnet produces the South Pole field equal to the MIN release point. Note that magnets produce weaker fields as the temperature increases.

In addition to the HS1, we offer a variety of South Pole and Either pole Hall Effect and Magnetoresistive sensors including multiple programmable sensors, North and South Pole output sensors, latching sensors, and sensors with speed/count and direction outputs. Check our website or contact us to discuss all of our magnetic speed, count, and position detection sensors.

HS1-L5, Electrical & Functional Specifications

ABSOLUTE MAX LIMITS	MIN	MAX	UNITS
Supply Voltage, Vcc	-30	+30	Volts DC
Voltage applied to output, 1 minute max	-25	+25	Volts
Current into output	--	50	mA
Current out of output	--	Vcc/5k	mA
Load Dump, 100mS Rs = 5 per ISO 7637-2 24V Truck Specification	--	200	Volts

ELECTRICAL SPECS	CONDITIONS	MIN	MAX	UNITS
Temperature Range *	Operating	-40	+110	Deg C
Supply Voltage, Vcc	Over temperature	+4.05	+25	Volts DC
Supply Current, Output Off	Into Vcc	+1	+5.5	mA
Frequency Range		0	20	kHz
Saturation Voltage Low, Vol	Vcc=24V, Rload>100k	0	0.7	Volts
Output Voltage High, Voh	Vcc=24V, Rload>100k	18	24	Volts
Pull up Resistor	Internal, Vcc to Vout	4.9	5.1	k Ohms
Output Rise Time 10-90%	Cout < 100pF	--	8.0	uS
Output Fall Time 90-10%	Cout < 100pF	--	2.0	uS
ESD **	Nondestructive	--	2000	Volts
EMI **	20k to 1 G Hz	--	100	V/M

* T max = 150°C is available, contact factory

** Similar Product Qualified

MAGNETIC CHARACTERISTICS	MIN	TYP	MAX	UNITS
Operate Point over temp	32	55	77	Gauss
Release Point over temp	17	35	54	Gauss
Hysteresis	9	20	28	Gauss

Rev A

Violet specs are 100 % tested at 20°C before shipping

**CHARACTERISTIC-OPTION
MARKED ON THIS SURFACE
XX = ELECTRICAL OPTION**

**AIR
GAP**

N S

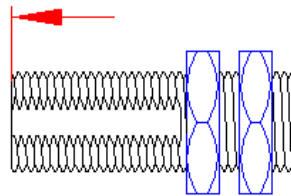

**DATE CODE,
THIS SURFACE**

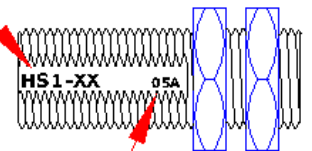

**NO ORIENTATION
REQUIRED**